

Installation instruction for light panels LM 01 / 03/ 05

1., Fastening of light panels

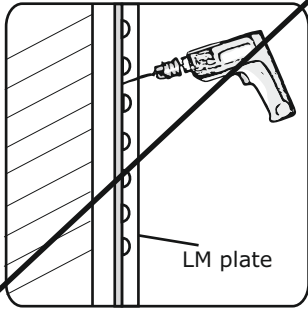

When fixing the light panels LM, do only use the drill holes made by the factory. Additional drilling may cause breakages in the panel, tearing of LED channels or damages in insulation. All these will inevitably implement the destruction of the light panel.

2., Usage of spacing washer

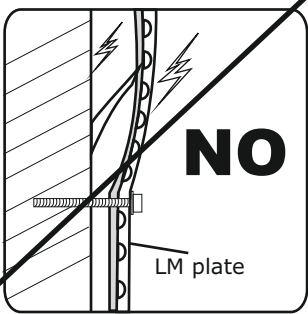

Prevent the insulating sheet on the backside from any damages.

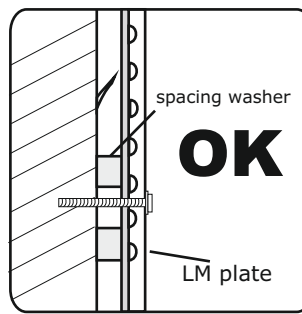

Use adequate plastic or rubber spacing washers on uneven surfaces.

3., Wiring of light panels to converters

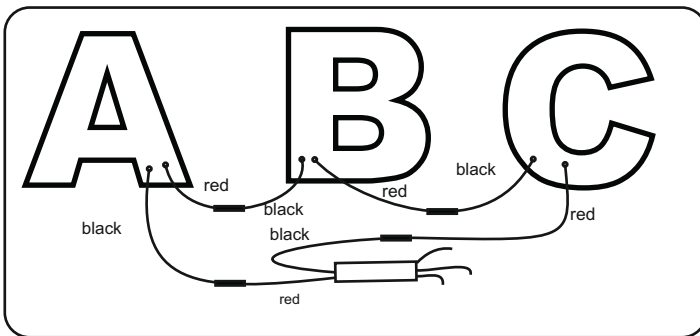

S-E-R-I-E-S C-O-N-N-E-C-T-I-O-N!

Always connect a red wire to a black one as shown in the wiring diagram.

Attention!

Inversion of the wires can cause damages and malfunction! Do only use convenient cables and watch out for waterproof connection!

In case of converters already pre-installed on the light panel, only the power supply connection has to be made.

4., Proper connection of wires

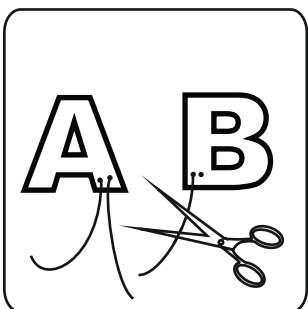

1., Cut wires to length

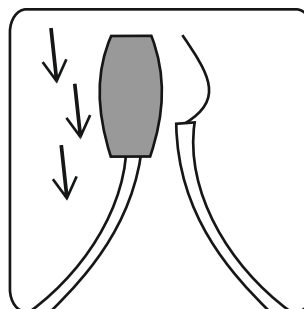

2., Impose shrink hose on

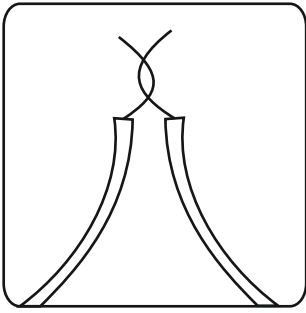

3., Strip 2-3cm of insulation and twist wires

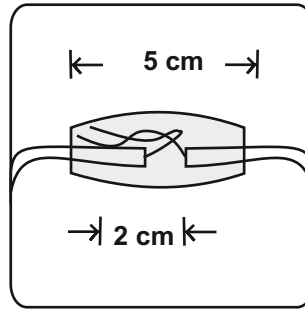

4., Turn wires down and position middle of the hose over the twisted wires

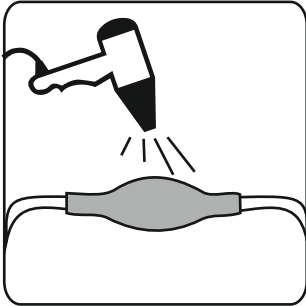

5., Heat hose with hot air or fire until the joint has been completely closed

5., Exposure to water

Although the light panels are IP67, do not keep them permanently under water. Keep distance from backside. Optionally drill water holes.